



H750

Standing flowerbed

Specifications

(mm)

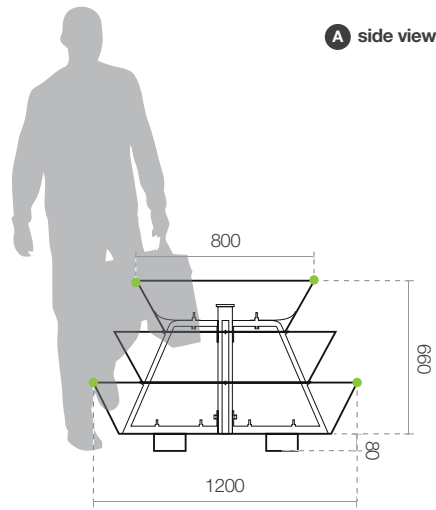

! Beware of imitations!

It is impossible to copy quality and safety. Only products branded with Terra's sign can provide the highest quality, safety and accuracy of execution.

Product protected by patent

▼ P 379058

Registered design

▼ Wp 9324-25

Made in EU

Warranty 24 months

Number of rings	3	Weight before planting	58 kg
Capacity	373 liters	weight after planting	190 - 370 kg
total height	740 mm	Estimated amount of seedlings	40 - 50 pieces
Base diameter	1200 mm	Warranty	24 months

Weight depending on the type of soil and its moisture

Terra's Cascading Flower Towers include a 2-year warranty program called "DOOR TO DOOR". In practice it is an extensive system of support and technical assistance, as well as an extremely efficient service guarantee. Product's flaws will promptly be fixed by our service team in any place designated or new products will be delivered.

Colours (DUPLEX)



DUPLEX System

The combination of the zinc coating and a layer of structural polyester powder paint guarantee a resistant protection surface, which durability can be defined as a doubled product of the sum of these two coatings.

Production method

- laser-cut rings
- rings welded in MAG / TIG technology
- all the elements are hot dip zinc coated
- powder coated rings (DUPLEX system)

Safety

- rubber gasket on each rings
- no sharp edges
- heavy and stable
- high resistance to vandalism
- can be fixed to the ground



H750

Standing flowerbed

Transport (mm)

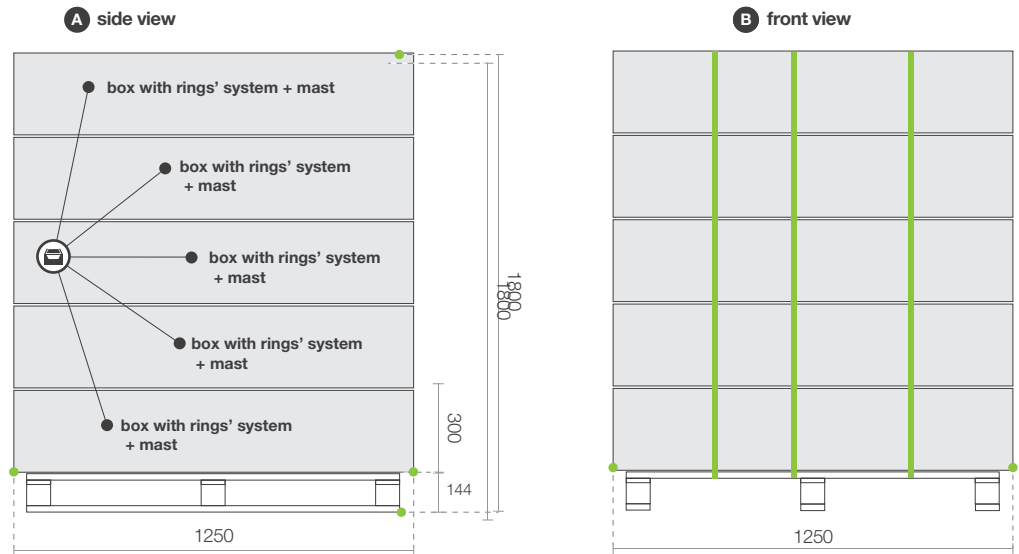

 SET PACKED IN A BOX

UP TO **5** SETS FOR A EURO PALLET

Set content

Lower pan with legs	1 item	Mast	1 item
Rings	2 items	Span	4 items
Screw 10x50	10 items	Security flat bar	2 items
Screw 10x90	4 items	gasket	10 m

Additional accessories

 anti-theft system

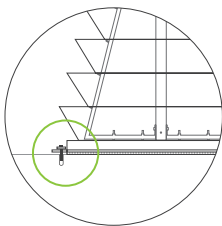

A

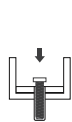

side view

B

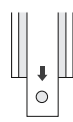

upper view

 mobile system

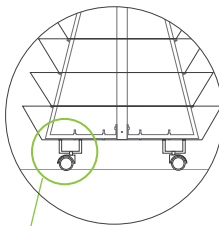

Optional fixing



 transport module

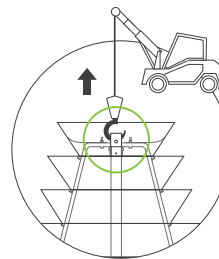

A



front view

B



side view

 watering system

TerraClick Tif

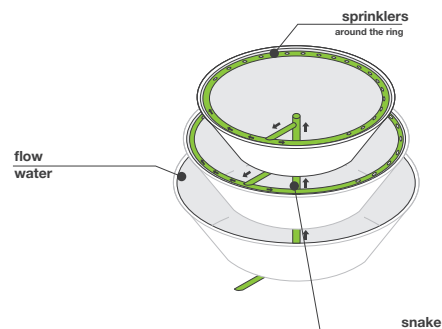

- number of lines in the system: 2
- type of connector: GEKA
- flow of drippers: 2 - 3 l/h
- pressure: 0,5 - 4 atm
- opening pressure of the anti-drip: 0,4 atm
- closing pressure of the anti-drip: 0,2 atm
- hose type: **new generation**
resistant to chemicals and acidification

